

Victaulic® Grooved Coupling

Style 31



Patented

1.0 PRODUCT DESCRIPTION

Available Sizes

- 2 – 36"/DN80 – DN900

Pipe Material

- Ductile Iron with a minimum wall thickness of ANSI/AWWA C151/A21.51, Class 53

Maximum Working Pressure

- Up to 500 psi/3450 kPa

Function

- Provides a fully restrained pipe joint to the published maximum allowable working pressure.
- Joints are rigid or flexible depending on groove style.
- Rigid joints resist axial and angular movement.
- Flexible joints allow for restrained axial and angular movement to the couplings published capabilities.

2.0 CERTIFICATION/LISTINGS



Coupling design, materials and testing conform to the requirements of AWWA C606 standard for Grooved and Shouldered Joints.

NOTES

- Refer to Victaulic [publication 10.01](#) for details

ALWAYS REFER TO ANY NOTIFICATIONS AT THE END OF THIS DOCUMENT REGARDING PRODUCT INSTALLATION, MAINTENANCE OR SUPPORT.

System No.		Location	
Submitted By		Date	

Spec Section		Paragraph	
Approved		Date	

3.0 SPECIFICATIONS – MATERIAL

Housing: Ductile iron conforming to ASTM A536, Grade 65-45-12. Ductile iron conforming to ASTM A395, Grade 65-45-15, is available upon special request.

Housing Coating: (specify choice)

- Standard: Phenolic Alkyd Primer (2.5 mil).
- Optional: Orange enamel.
- Optional: Coal tar epoxy coating (3 mils).
- Organic zinc primer (3 mils).
- Bituminous coating.

NOTE

- Others available, contact Victaulic.

Gasket: (specify choice¹)

Grade “M” FlushSeal™

Halogenated Butyl (Brown color code). Temperature range –20°F to +200°F/–29°C to +93°C. Specially compounded to conform to ductile pipe surfaces. Recommended for water service within the specified temperature range plus a variety of dilute acids, oil-free air, and many chemical services. UL classified in accordance with ANSI/NSF 61 for cold +86° F/+30°C potable water service. NOT RECOMMENDED FOR PETROLEUM SERVICES.

Grade “S” FlushSeal™

Nitrile (Red color code). Temperature range –20°F to +180°F/–29°C to + 82°C. Specifically compounded to conform to ductile pipe surfaces. Recommended for petroleum products, air with oil vapors, vegetable and mineral oils within the specified temperature range; except hot air over +140° F/+60° C and water over +150° F/+66°C. NOT RECOMMENDED FOR HOT WATER SERVICES.

¹ Services listed are General Service Guidelines only. It should be noted that there are services for which these gaskets are not compatible. Reference should always be made to the latest [Victaulic Seal Selection Guide](#) for specific gasket service guidelines and for a listing of services which are not compatible.

Bolts/Nuts: (specify choice)

Standard: Carbon steel oval neck track bolts meeting the mechanical property requirements of ASTM A449 (imperial) and ISO 898-1 Class 9.8 (M10-M16) Class 8.8 (M20 and greater). Carbon steel hex nuts meeting the physical and chemical requirements of ASTM A563 Grade B (imperial - heavy hex nuts) and ASTM A563M Class 9 (metric - hex nuts). Track bolts and hex nuts are zinc electroplated per ASTM B633 ZN/FE5, finish Type III (imperial) or Type II (metric).

Optional: Stainless steel oval neck track bolts meeting the requirements of ASTM F593, Group 2 (316 stainless steel), condition CW. Stainless steel heavy hex nuts meeting the requirements of ASTM F594, Group 2 (316 stainless steel), condition CW, with galling-resistant coating.²

² Optional bolts/nuts are available in imperial size only.

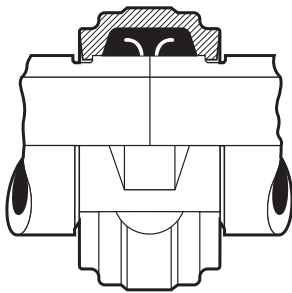

Exaggerated for Clarity

4.0 DIMENSIONS

Style 31

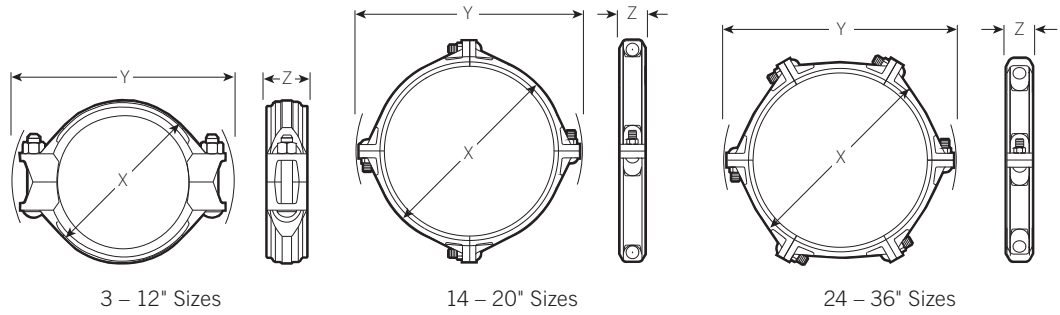

Pipe Size		Bolt/Nut ³		Dimensions			Weight
Nominal inches DN	Actual Outside Diameter inches mm	Qty.	Size inches	X inches mm	Y inches mm	Z inches mm	Approximate (Each) lb kg
3 DN80	3.960 100.6	2	1/2 x 2 3/4	5.50 140	7.63 194	2.13 54	4.8 2.2
4 DN100	4.800 121.9	2	5/8 x 3 1/4	6.25 159	9.20 234	2.09 53	7.5 3.4
6 DN150	6.900 175.3	2	5/8 x 3 1/4	8.28 210	11.19 284	2.22 56	9.4 4.3
8 DN200	9.050 229.9	2	3/4 x 5	10.74 273	14.33 364	2.59 66	16.5 7.5
10 DN250	11.100 281.9	2	3/4 x 5	12.84 326	16.44 418	2.75 70	22.5 10.2
12 DN300	13.200 335.3	2	7/8 x 5	15.27 388	19.16 487	2.75 70	30.0 14.0
14 DN350	15.300 388.6	4	1 x 3 1/2	17.21 437	21.96 558	2.75 70	40.8 18.5
16 DN400	17.400 442.0	4	1 x 3 1/2	19.90 505	23.96 609	3.50 89	61.3 27.8
18 DN450	19.500 495.3	4	1 x 3 1/2	22.03 560	26.33 669	3.50 89	80.0 36.3
20 DN500	21.600 548.6	4	1 1/8 x 4	24.13 613	28.69 729	3.50 89	76.0 34.5
24 DN600	25.800 655.3	6	1 1/8 x 4	28.31 719	33.06 840	3.50 89	104.0 47.2
30 DN750	32.000 812.8	6	1 1/8 x 4	35.02 890	39.39 1001	4.38 111	162.0 73.5
36 DN900	38.300 972.8	6	1 1/8 x 4	41.56 1056	46.04 1169	4.44 113	200.0 90.7

³ Number of bolts required equals number of housing segments. Metric thread size bolts are available (color coded gold) for all coupling sizes upon request. Contact Victaulic for details.

NOTES

- WARNING: Depressurize and drain the piping system before attempting to install, remove, or adjust any Victaulic piping products.
- WARNING: FOR ONE TIME FIELD TEST ONLY, the Maximum Joint Working Pressure may be increased to 1 1/2 times the figures shown.

5.0 PERFORMANCE

Style 31

Size		Pipe End Separation ⁴	Deflect FR. C.L. ⁴		Maximum Joint Working Pressure ⁵	Maximum Permis. End Load ⁵
Nominal inches DN	Actual Outside Diameter inches mm	Allowable inches mm	Per Cplg. Degree	Pipe In./Ft. mm		
3 DN80	3.960 100.6	0 - 0.09 0 - 2.4	1° - 21'	0.28 23	500 3450	6200 27590
4 DN100	4.800 121.9	0 - 0.09 0 - 2.4	1° - 8'	0.21 17	500 3450	9000 40050
6 DN150	6.900 175.3	0 - 0.09 0 - 2.4	0° - 47'	0.14 12	400 2750	14950 66528
8 DN200	9.050 229.9	0 - 0.09 0 - 2.4	0° - 36'	0.11 9	400 2750	25600 113920
10 DN250	11.100 281.9	0 - 0.16 0 - 4.0	0° - 48'	0.15 13	350 2410	33850 150632
12 DN300	13.200 335.3	0 - 0.16 0 - 4.0	0° - 41'	0.13 11	350 2410	47.900 21150
14 DN350	15.300 388.6	0 - 0.16 0 - 4.0	0° - 35'	0.11 9	250 1725	45950 204470
16 DN400	17.400 442.0	0 - 0.25 0 - 6.4	0° - 49'	0.16 13	250 1725	59400 264330
18 DN450	19.500 495.3	0 - 0.25 0 - 6.4	0° - 44'	0.14 12	250 1725	74650 332190
20 DN500	21.600 548.6	0 - 0.25 0 - 6.4	0° - 40'	0.12 10	150 1035	54900 244305
24 DN600	25.800 655.3	0 - 0.25 0 - 6.4	0° - 33'	0.11 9	150 1035	78.400 34880
30 DN750	32.000 812.8	0 - 0.47 0 - 11.9	0° - 51'	0.17 14	150 1035	120570 536530
36 DN900	38.300 972.8	0 - 0.47 0 - 11.9	0° - 47'	0.15 13	150 1035	172815 769030

⁴ Allowable Pipe End Separation and Deflection figures show the maximum nominal range of movement available at each joint for pipe prepared to flexible cut grooved specifications. Pipe cut grooved to rigid cut grooved specifications does not permit expansion and contraction.

⁵ Working Pressure and End Load are total, from all internal and external loads, based on AWWA class 53 or higher ductile iron pipe radius cut grooved in accordance with Victaulic published radius cut groove dimensions.

NOTE

- WARNING: FOR ONE TIME FIELD TEST ONLY, the Maximum Joint Working Pressure may be increased to 1 ½ times the figures shown.

6.0 NOTIFICATIONS

WARNING



- Read and understand all instructions before attempting to install, remove, adjust, or maintain any Victaulic piping products.
- Depressurize and drain the piping system before attempting to install, remove, adjust, or maintain any Victaulic piping products.
- Wear safety glasses, hardhat, and foot protection.

Failure to follow these instructions could result in death or serious personal injury and property damage.

7.0 REFERENCE MATERIALS

[23.01: AWWA Ductile Iron Pipe - Grooved System](#)

[23.05: AWWA \(Cast\) Fittings](#)

[25.05: Radius Cut Groove Specifications](#)

[29.01: Terms and Conditions/Warranty](#)

[I-300: Field Installation Handbook](#)

[I-ENDCAP: Victaulic® End Caps Installation Instructions](#)

User Responsibility for Product Selection and Suitability

Each user bears final responsibility for making a determination as to the suitability of Victaulic products for a particular end-use application, in accordance with industry standards and project specifications, as well as Victaulic performance, maintenance, safety, and warning instructions. Nothing in this or any other document, nor any verbal recommendation, advice, or opinion from any Victaulic employee, shall be deemed to alter, vary, supersede, or waive any provision of Victaulic Company's standard conditions of sale, installation guide, or this disclaimer.

Intellectual Property Rights

No statement contained herein concerning a possible or suggested use of any material, product, service, or design is intended, or should be construed, to grant any license under any patent or other intellectual property right of Victaulic or any of its subsidiaries or affiliates covering such use or design, or as a recommendation for the use of such material, product, service, or design in the infringement of any patent or other intellectual property right. The terms "Patented" or "Patent Pending" refer to design or utility patents or patent applications for articles and/or methods of use in the United States and/or other countries.

Note

This product shall be manufactured by Victaulic or to Victaulic specifications. All products to be installed in accordance with current Victaulic installation/assembly instructions. Victaulic reserves the right to change product specifications, designs and standard equipment without notice and without incurring obligations.

Installation

Reference should always be made to the Victaulic installation handbook or installation instructions of the product you are installing. Handbooks are included with each shipment of Victaulic products, providing complete installation and assembly data, and are available in PDF format on our website at www.victaulic.com.

Warranty

Refer to the Warranty section of the current Price List or contact Victaulic for details.

Trademarks

Victaulic and all other Victaulic marks are the trademarks or registered trademarks of Victaulic Company, and/or its affiliated entities, in the U.S. and/or other countries.