

Style 232S Restrained Flexible Coupling

Victaulic Bolted Split-Sleeve Products (VBSP) Style 232S stainless steel couplings (formerly Depend-O-Lok FxF) provide a fully restrained, flexible pipe joint that satisfies the requirements set forth by the AWWA C227 Standard for Bolted, Split-Sleeve Restrained and Non-Restrained Couplings for Plain-End Pipe.

This style of coupling creates a restrained joint, commonly used in buried or exposed pipe applications for field joint connections where joint flexibility and thrust restraint is required. Typical applications include water and at wastewater treatment pipelines, ethanol and other chemical plant piping, pulp and paper industry piping and other applications where corrosion resistant, restrained flexible joints are required.

The dual-arched coupling body houses o-ring gaskets that provide the radial seal around the circumference of the pipe, while a sealing plate provides for the axial seal across the coupling body and pipe joint. The Style 232S coupling incorporates a restraint ring welded to each pipe end (furnished with the coupling) allowing the coupling housing to straddle the restraint rings, and confining the rings under the coupling body in order to create a fully restrained joint. The coupling housing and restraint ring welds are designed to accommodate hoop stress and end loads to meet system pressure requirements. Style 232S restrained flexible couplings also perform at negative pipe pressures up to full vacuum. The o-ring gasket is not pressure responsive and therefore does not require internal pipe pressure to assist with the seal. The arched cross-sectional design provides stiffness to resist forces encountered during negative pressure (submerged) or vacuum service.

Style 232S couplings are available in standard nominal sizes from 3 – 96"/80 – 2400 mm with larger sizes available based on design and application requirements. The Style 232S restrained coupling can accommodate operating pressures up to 300 psi/2065 kPa depending on the actual pipe diameter and wall thickness. For pressures and sizes not shown in the dimension and performance tables contact Victaulic for information on our engineered products.

Victaulic restrained couplings provide a flexible pipe connection and are not designed or intended to transfer significant shear or bending loads across the pipe joint. Therefore, a single coupling will not allow for differential settlement to occur at the joint. However, a minimum of two flexible couplings designed to allow dynamic (in-service) deflection, and installed in combination, can be used to accommodate differential settlement at a pipe joint or between a pipeline and a structure. Victaulic recommends Style 233/233S couplings for this purpose as they are specifically designed to allow for dynamic deflection and provide thrust restraint at the joint. Refer to publications 60.07 and 60.08 for product details and 26.20 for guidelines regarding the use of these couplings in differential settlement applications.

All flexible mechanical couplings should be properly supported to minimize or eliminate undesirable loads at the joint. Pipe support requirements are defined within the Victaulic Application Guidelines document. Please see publication 26.20.

For proper closure tool selection see column marked Tool Type on pages 6-7.



3 – 96"/80 – 2400mm

JOB/OWNER	CONTRACTOR	ENGINEER
System No. _____	Submitted By _____	Spec Sect _____ Para _____
Location _____	Date _____	Approved _____
		Date _____

www.victaulic.com

VICTAULIC IS A REGISTERED TRADEMARK OF VICTAULIC COMPANY. © 2013 VICTAULIC COMPANY. ALL RIGHTS RESERVED.

REV_J



Style 232S Restrained Flexible Coupling

PRODUCT GUIDE

Product Style Guide			
Submittal Number	Style Number	Coupling/Body Material	Application
60.01	230	Carbon Steel	Non-Restrained Coupling
60.02	230S	Stainless Steel	Non-Restrained Coupling
60.03	231	Carbon Steel	Expansion Coupling
60.04	231S	Stainless Steel	Expansion Coupling
60.05	232	Carbon Steel	Restrained Coupling
60.06	232S	Stainless Steel	Restrained Coupling
60.07	233	Carbon Steel	Restrained Coupling For Dynamic Joint Deflection
60.08	233S	Stainless Steel	Restrained Coupling For Dynamic Joint Deflection
60.09	234	Carbon Steel	Restrained Single-Gasket Coupling
60.10	234S	Stainless Steel	Restrained Single-Gasket Coupling

SEGMENTED COUPLINGS

The Style 232S dimension tables list the minimum number of coupling housing segments for a particular pipe size. For special applications, restrained split sleeve couplings are available in two (or more) segments to allow for installation of the coupling over an existing pipe joint or to facilitate ease of handling for larger size couplings. The o-ring gaskets (except Silicone) can be furnished "split" to allow for field bonding when an existing pipe joint configuration does not allow for installation of a complete o-ring onto the pipe end.

BODY TYPE

Cross-Sections

NOTE: Body type is not optional and will be determined by system requirements.



Type 1 coupling is the basic split-sleeve coupling that restrains pipe ends and is generally used for smaller diameter, low pressure applications.



Type 2 coupling is a shouldered coupling. This is a heavy duty coupling to accommodate higher pressures for certain pipe diameters. The shoulders welded to the edge of the coupling body provide a vertical bearing surface for the restraint rings and provide additional cross-sectional stiffness.

Style 232S Restrained Flexible Coupling

COUPLING COMPONENTS

1. **Body** – Dual arch cross-section.
2. **Shoulders (Type 2 only)** – Provide additional stiffness, allow for larger o-ring gasket and provide vertical bearing surface for restraint rings.
3. **Closure Plates** – Low profile bolt pads for installation and tightening of coupling; gap between plates of installed coupling allows for field flexibility.
4. **Sealing Plate** – Provides axial seal across the coupling body and pipe joint.
5. **O-ring Gaskets** – Provide circumferential seal.
6. **Fasteners**
 - Studs – High Strength Threaded Rod
 - Nuts – Heavy Hex Nuts
 - Washers – SAE small pattern flat washers
7. **Restraint Rings** – Attached to pipe ends to create a restrained joint.

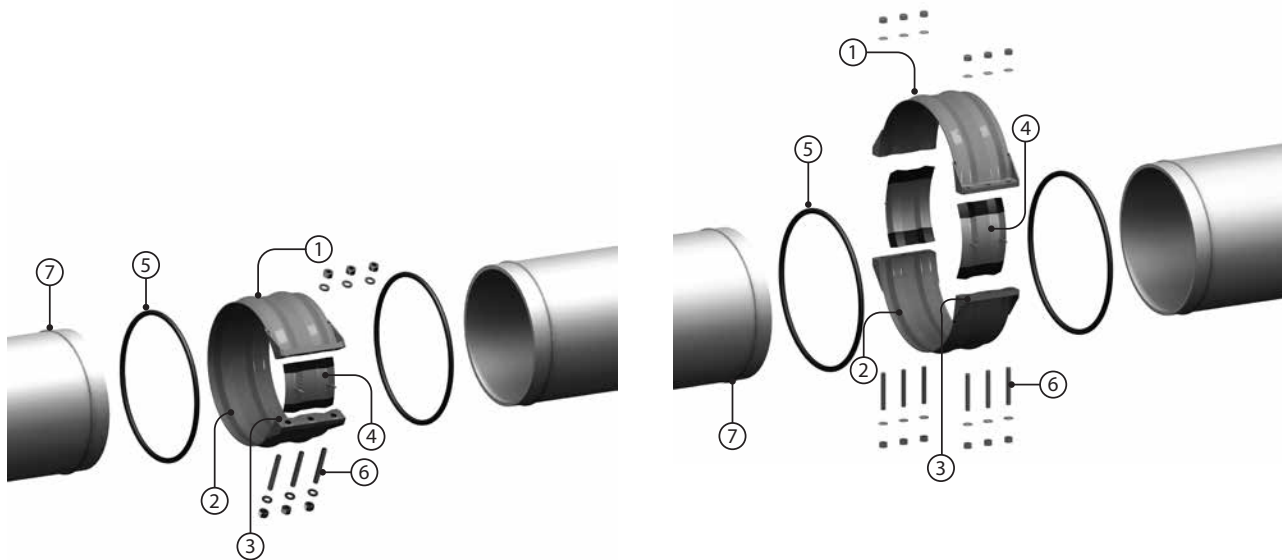

ONE SEGMENT HOUSING

TWO SEGMENT HOUSING

Style 232S Restrained Flexible Coupling

MATERIAL SPECIFICATIONS

Body

Stainless Steel conforming to ASTM A240 316/316L

Shoulders (Type 2)

Stainless Steel conforming to ASTM A240 316L

Closure Plates

Stainless Steel conforming to 316L

Sealing Plate

Stainless Steel conforming to ASTM A240 316L

O-ring Gaskets

Standard (Specify choice on order):

- **EPDM** -30°F to +230°F/-34°C to +110°C
Cold and hot water within allowable temperature range; dilute acids; excellent resistance to the deteriorative effects of ozone, oxygen, heat and most chemicals not involving hydrocarbons. NOT RECOMMENDED FOR PETROLEUM SERVICES.
- **Silicone** -30°F to +350°F/-34°C to +177°C
Dry, hot air applications; excellent resistance to many chemicals. NOT RECOMMENDED FOR HOT WATER OR STEAM APPLICATIONS.
- **Isoprene** -40°F to +160°F/-40°C to +71°C
Water; salt water; sewage; good resistance to oxygen and dilute acids

Services listed are general service recommendations only. Refer to a chemical elastomer guide for specific applications and suitability of gasket material for services that are not listed.

Optional gasket (specify choice on order):

- **Nitrile** -20°F to +180°F/-28°C to +82°C
Water; petroleum products, vegetable and mineral oils; air with oil vapors within allowable temperature range; good resistance to hydrocarbons; acids and bases.
- **Fluoroelastomer** +20°F to +300°F/-7°C to +149°C
Outstanding resistance to heat and most chemicals.
- **Neoprene** -30°F to +180°F/-34°C to +82°C
Water and wastewater; good resistance to ozone, effects of UV and some oils.

Restraint Rings

Stainless Steel conforming to ASTM A276 316L

Permanent Fasteners

Studs - Stainless Steel conforming to ASTM A193 Grade B8M 316 Class 2

Nuts - Heavy hex nuts

Stainless Steel conforming to ASTM A194 Grade 8M 316

Washers - Stainless Steel Type 316 SAE pattern

Installation Fasteners (for installation purposes only)

Studs - Carbon Steel conforming to ASTM A193 Grade B7 zinc plated

Nuts - Heavy hex nuts

Carbon Steel conforming to ASTM A194 Grade 2H zinc plated

Washers - Carbon Steel SAE small pattern flat washers conforming to ASTM F436 SAE pattern zinc plated

Style 232S Restrained Flexible Coupling

PIPE END DIMENSIONAL TOLERANCE AND OVALITY

For specific pipe diameter tolerances, pipe ovality (roundness) requirements and minimum/maximum pipe diameter allowance, refer to the tables included in the Installation Manuals (below) and 26.20 Application Guidelines.

I-232.S1 - Styles 232/232S Restrained Coupling (Types 1 & 2, One-Segment)

I-232.S2 - Styles 232/232S Restrained Coupling (Types 1 & 2, Two-Segments)

Style 232S Restrained Flexible Coupling

DIMENSIONS

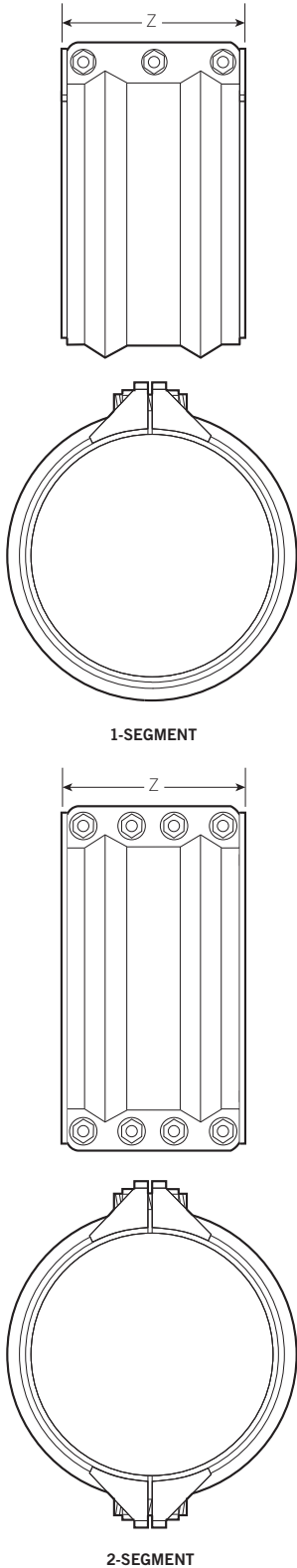

1-SEGMENT

2-SEGMENT

(1) Nominal Pipe Size In./mm	(2) Actual Pipe O.D. Range In./mm	(3) Maximum Working Pressure psi/kPa	Coupling Dimensions		(4) Min. No. of Coupling Segments	No. of Fasteners - Fastener Dimensions Dia. x Length In. x In.	(5) Approximate Weight Each Lbs/Kg.	Body Type	(6) Tool Type
			Body Thickness In.	Width (Z) In./mm					
3 80	2.88 - 3.50 73.2 - 88.9	300 2065	14 ga.	5.25 133.4	1	3 - ½ x 3 ¼	5.0 2.3	1	A
4 100	3.63 - 4.88 92.2 - 124.0	300 2065	14 ga.	5.25 133.4	1	3 - ½ x 3 ¼	5.0 2.3	1	A
6 150	5.00 - 6.88 127 - 174.8	300 2065	12 ga.	8.00 203.2	1	3 - ½ x 3 ¼	12.0 5.4	1	A
8 200	7.00 - 8.88 177.8 - 225.6	200 1375	11 ga.	10.00 254.0	1	3 - ⅝ x 5	21.0 9.5	1	B,C
		300 2065	10 ga.	10.50 266.7	1	3 - ⅝ x 5	39.0 17.7	2	B,C
10 250	9.00 - 10.88 228.6 - 276.4	200 1375	10 ga.	10.00 254.0	1	3 - ⅝ x 5	24.0 10.9	1	B,C
		250 1725	10 ga.	10.50 266.7	1	3 - ⅝ x 5	42.0 19.1	2	B,C
12 300	11.00 - 12.88 279.4 - 327.2	150 1035	10 ga.	10.00 254.0	1	3 - ⅝ x 5	28.0 12.7	1	B,C
		250 1725	⅜	10.50 266.7	1	3 - ¾ x 6	53.0 24.0	2	B,C
14 350	13.00 - 14.88 330.2 - 378.0	100 690	10 ga.	10.00 254.0	1	3 - ⅝ x 5	31.0 14.1	1	B,C
		250 1725	⅜	10.50 266.7	1	3 - ¾ x 6	59.0 26.8	2	B,C
16 400	15.00 - 16.88 381.0 - 428.8	75 515	⅜	10.00 254.0	1	3 - ¾ x 6	48.0 21.8	1	B,C
		250 1725	⅜	10.50 266.7	1	3 - ¾ x 6	66.0 29.9	2	B,C
18 450	17.00 - 18.88 431.8 - 479.6	50 345	⅜	10.00 254.0	1	3 - ¾ x 6	52.0 23.6	1	B,C
		200 1375	⅜	10.50 266.7	1	3 - ¾ x 6	72.0 32.7	2	B,C
20 500	19.00 - 21.88 482.6 - 55.8	25 170	⅜	10.00 254.0	1	3 - ¾ x 6	56.0 25.4	1	B,C
		200 1375	⅜	10.50 266.7	1	3 - ¾ x 6	77.0 34.9	2	B,C
24 600	22.00 - 26.88 558.8 - 682.8	25 170	⅜	10.00 254.0	1	3 - ¾ x 6	66.0 29.9	1	B,C
		100 690	⅜	10.50 266.7	1	3 - ¾ x 6	91.0 41.3	2	B,C
		200 1375	¼	12.50 317.5	1	4 - ¾ x 6	134.0 60.8	2	C
30 750	27.00 - 32.88 685.8 - 835.2	100 690	⅜	10.50 266.7	1	3 - ¾ x 6	109.0 49.4	2	B,C
		150 1035	¼	12.50 317.5	1	4 - ¾ x 6	162.0 73.5	2	C
		200 1375	⅜	12.50 317.5	2	8 - ⅞ x 8	342.0 155.1	2	C
36 900	33.00 - 38.88 838.2 - 2511.6	100 690	⅜	10.50 266.7	1	3 - ¾ x 6	127.0 56.6	2	B,C
		150 1035	¼	12.50 317.5	1	4 - ¾ x 6	190.0 86.2	2	C
		175 1200	⅜	12.50 317.5	2	8 - ⅞ x 8	394.0 178.7	2	C
		200 1375	½	14.50 368.3	2	8 - 1 x 8	594.0 269.4	2	C

- (1) Couplings must be used on pipe with a minimum wall thickness that meets the requirements of C220 for stainless steel pipe.
- (2) For actual Pipe O.D. round down to the nearest ⅛" to determine proper coupling size required.
- (3) For allowable test or transient pressure, the maximum working pressure may be increased to 1½ times the values shown.
- (4) 1-segment couplings may be available as 2-segment couplings to allow for in-place pipe installations. Contact Victaulic for details.
- (5) Coupling weights are based on nominal pipe diameter and include all accessories. Weight may vary based on actual size of pipe.
- (6) Closure Tool Recommendations:*

A= CTM-01 Small Manual Closure Tool C= CTH-01 10-Ton Hydraulic Closure Tool
 B= CTM-02 Large Manual Closure Tool

*For more details on closure tools refer to page 13.

Note: The data in this table applies when stainless steel couplings are being used on stainless steel pipe.

Style 232S Restrained Flexible Coupling

DIMENSIONS

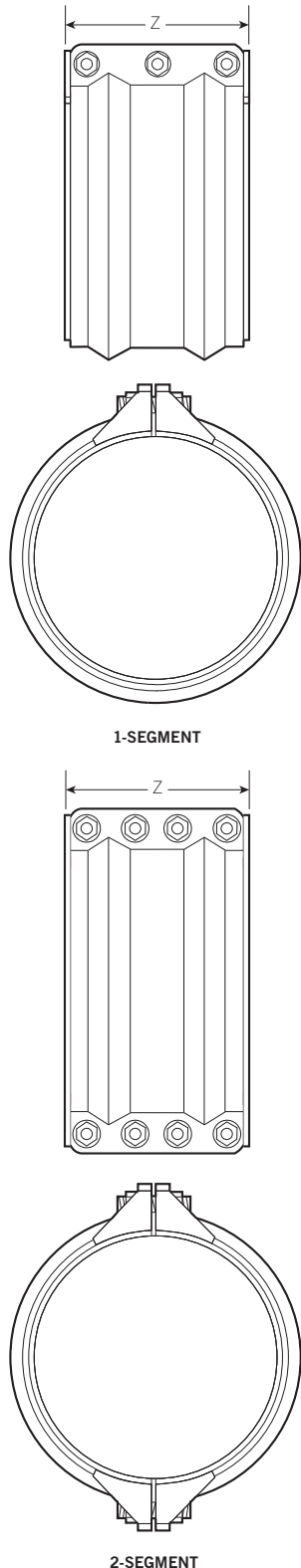

(1) Nominal Pipe Size In./mm	(2) Actual Pipe O.D. Range In./mm	(3) Maximum Working Pressure psi/kPa	Coupling Dimensions		(4) Min. No. of Coupling Segments	No. of Fasteners - Fastener Dimensions Dia. x Length In. x In.	(5) Approximate Weight Each Lbs/Kg.	Body Type	(6) Tool Type
			Body Thickness In.	Width (Z) In./mm					
42 1050	39.00 - 44.88 990.6 - 1140.0	100 690	1/4	12.50 317.5	1	4 - 3/4 x 6	217.0 98.4	2	C
		150 1035	3/8	12.50 317.5	2	8 - 7/8 x 8	442.0 200.5	2	C
		200 1375	1/2	14.50 368.3	2	8 - 1 x 8	670.0 303.9	2	C
48 1200	45.00 - 50.88 1143.0 - 1292.4	50 345	1/4	12.50 317.5	1	4 - 3/4 x 6	244.0 110.7	2	C
		100 690	3/8	12.50 317.5	2	8 - 7/8 x 8	489.0 221.8	2	C
		150 1035	1/2	14.50 368.3	2	8 - 1 x 8	744.0 337.5	2	C
54 1350	51.00 - 56.88 1295.4 - 1444.8	50 345	1/4	12.50 317.5	1	4 - 7/8 x 8	298.0 135.2	2	C
		100 690	3/8	12.50 317.5	2	8 - 7/8 x 8	523.0 237.2	2	C
		150 1035	1/2	14.50 368.3	2	8 - 1 x 8	819.0 371.5	2	C
60 1500	57.00 - 62.88 1447.8 - 1597.2	50 345	1/4	12.50 317.5	2	8 - 7/8 x 8	376.0 170.6	2	C
		100 690	3/8	12.50 317.5	2	8 - 7/8 x 8	571.0 259.0	2	C
		150 1035	1/2	14.50 368.3	2	8 - 1 x 8	894.0 405.5	2	C
66 1650	63.00 - 68.88 1600.2 - 1749.6	50 345	3/8	12.50 317.5	2	8 - 7/8 x 8	606.0 274.9	2	C
		150 1035	1/2	14.50 368.3	2	8 - 1 x 8	951.0 431.4	2	C
		50 345	3/8	12.50 317.5	2	8 - 7/8 x 8	654.0 296.6	2	C
72 1800	69.00 - 74.88 1752.6 - 1902.0	100 690	1/2	14.50 368.3	2	8 - 1 x 8	1027.0 465.8	2	C
		50 345	3/8	12.50 317.5	2	8 - 7/8 x 8	691.0 313.4	2	C
78 1950	75.00 - 80.88 1905 - 2054.4	100 690	1/2	14.50 368.3	2	8 - 1 x 8	1102.0 499.9	2	C
		50 345	3/8	12.50 317.5	2	8 - 7/8 x 8	739.0 335.2	2	C
84 2100	81.00 - 86.88 2057.4 - 2206.8	100 690	1/2	14.50 368.3	2	8 - 1 x 8	1160.0 526.2	2	C
		50 345	3/8	12.50 317.5	2	8 - 7/8 x 8	776.0 352.0	2	C
90 2250	87.00 - 92.88 2209.8 - 2359.2	100 690	1/2	14.50 368.3	2	8 - 1 x 8	1217.0 552.0	2	C
		50 345	3/8	12.50 317.5	2	8 - 7/8 x 8	834.0 378.3	2	C
96 2400	93.00 - 102.00 2362.2 - 2590.8	75 520	1/2	14.50 368.3	2	8 - 1 x 8	1307.0 592.8	2	C

- (1) Couplings must be used on pipe with a minimum wall thickness that meets the requirements of C220 for stainless steel pipe.
 - (2) For actual Pipe O.D. round down to the nearest 1/8" to determine proper coupling size required.
 - (3) For allowable test or transient pressure, the maximum working pressure may be increased to 1 1/2 times the values shown.
 - (4) 1-segment couplings may be available as 2-segment couplings to allow for in-place pipe installations. Contact Victaulic for details.
 - (5) Coupling weights are based on nominal pipe diameter and include all accessories. Weight may vary based on actual size of pipe.
 - (6) Closure Tool Recommendations:
 - A= CTM-01 Small Manual Closure Tool
 - B= CTM-02 Large Manual Closure Tool
 - C= CTH-01 10-Ton Hydraulic Closure Tool
- *For more details on closure tools refer to page 13.
 Note: The data in this table applies when stainless steel couplings are being used on stainless steel pipe.

Style 232S Restrained Flexible Coupling

PERFORMANCE

Nominal Pipe Size In./mm	(1)			Body Type	(2) (3)		(3) (4)	(5)
	Maximum Working Pressure psi/kPa Carbon Steel	Maximum Working Pressure psi/kPa Stainless Steel	Maximum Working Pressure psi/kPa Ductile Iron		Pipe End Separation Min - Max In./mm	Max. Allow. Static Deflection Degrees	Max. Permissible End Load lbf/N	
3 80	300 2065	300 2065	300 2065	1	0.19 - 0.38 4.8 - 9.7	6° 0'	2121 9433	
4 100	300 2065	300 2065	300 2065	1	0.19 - 0.38 4.8 - 9.7	4° 45'	3770 16769	
6 150	300 2065	300 2065	300 2065	1	0.25 - 0.50 6.4 - 12.7	4° 15'	8482 37731	
8 200	200 1375	200 1375	200 1375	1	0.38 - 0.75 9.7 - 19.1	4° 0'	10053 44718	
	300 2065	300 2065	300 2065	2	0.38 - 0.75 9.7 - 19.1	4° 0'	15080 67078	
10 250	200 1375	200 1375	200 1375	1	0.38 - 0.75 9.7 - 19.1	3° 30'	15708 69873	
	250 1725	250 1725	250 1725	2	0.38 - 0.75 9.7 - 19.1	3° 30'	19635 87341	
12 300	150 1035	150 1035	150 1035	1	0.38 - 0.75 9.7 - 19.1	3° 15'	16965 75462	
	250 1725	250 1725	250 1725	2	0.38 - 0.75 9.7 - 19.1	3° 15'	28274 125771	
14 350	100 690	100 690	100 690	1	0.38 - 0.75 9.7 - 19.1	3° 0'	15394 68475	
	250 1725	250 1725	250 1725	2	0.38 - 0.75 9.7 - 19.1	3° 0'	38485 171188	
16 400	75 515	75 515	75 515	1	0.38 - 0.75 9.7 - 19.1	2° 30'	15080 67078	
	250 1725	250 1725	200 1375	2	0.38 - 0.75 9.7 - 19.1	2° 30'	50265 223592	
18 450	50 345	50 345	50 345	1	0.38 - 0.75 9.7 - 19.1	2° 15'	12723 56597	
	200 1375	200 1375	175 1200	2	0.38 - 0.75 9.7 - 19.1	2° 15'	50894 226387	
20 500	25 170	25 170	25 170	1	0.38 - 0.75 9.7 - 19.1	2° 0'	7854 34936	
	200 1375	200 1375	150 1035	2	0.38 - 0.75 9.7 - 19.1	2° 0'	62832 279490	
24 600	25 170	25 170	25 170	1	0.38 - 0.75 9.7 - 19.1	1° 45'	11310 50308	
	100 690	100 690	100 690	2	0.38 - 0.75 9.7 - 19.1	1° 45'	45239 201233	
	200 1375	200 1375	200 1375	2	0.63 - 1.00 16.0 - 25.4	1° 45'	90478 402466	
30 750	100 690	100 690	100 690	2	0.38 - 0.75 9.7 - 19.1	1° 15'	70686 314426	
	150 1035	150 1035	150 1035	2	0.63 - 1.00 16.0 - 25.4	1° 15'	106029 471639	
	200 1375	200 1375	150 1035	2	0.63 - 1.00 16.0 - 25.4	1° 15'	141372 628853	
36 900	100 690	100 690	75 515	2	0.38 - 0.75 9.7 - 19.1	1° 7'	101788 452774	
	150 1035	150 1035	125 860	2	0.63 - 1.00 16.0 - 25.4	1° 7'	152681 679161	
	175 1200	175 1200	125 860	2	0.63 - 1.00 16.0 - 25.4	1° 7'	178128 792354	
	200 1375	200 1375	175 1200	2	0.63 - 1.00 16.0 - 25.4	1° 7'	203575 905548	

- (1) For allowable test or transient pressure, the maximum working pressure may be increased to 1½ times the value shown.
- (2) Pipe end separations shown in the table assume the pipe is in a non-deflected state. Maximum allowable axial pipe movement at the joint is the difference between the maximum and minimum pipe separation. At maximum pipe end separation, axial movement can only occur via pipe expansion into the joint and vice versa.
- (3) Pipe end movement and deflection are non-concurrent.
- (4) Published static deflection values are intended for installation only. For allowable in-service or dynamic deflection, use ½ of the published static values. The coupling closure should be located 90 degrees from the direction of joint deflection.
- (5) The maximum permissible end loads listed in the table are calculated using the nominal pipe O.D. The actual maximum permissible end load will be less or greater than the published figures depending on the actual pipe O.D.

Style 232S Restrained Flexible Coupling

PERFORMANCE

Nominal Pipe Size In./mm	(1)			Body Type	(2) (3) Pipe End Separation Min - Max In./mm	(3) (4) Max. Allow. Static Deflection Degrees	(5) Max. Permissible End Load lbf/N
	Maximum Working Pressure psi/kPa Carbon Steel	Maximum Working Pressure psi/kPa Stainless Steel	Maximum Working Pressure psi/kPa Ductile Iron				
42 1050	100 690	100 690	100 690	2	0.63 - 1.00 16.0 - 25.4	1° 0'	138544 616276
	150 1035	150 1035	125 860	2	0.63 - 1.00 16.0 - 25.4	1° 0'	207816 924413
	200 1375	200 1375	150 1035	2	0.63 - 1.00 16.0 - 25.4	1° 0'	277088 1232551
48 1200	50 345	50 345	50 345	2	0.63 - 1.00 16.0 - 25.4	0° 52'	90478 402466
	100 690	100 690	100 690	2	0.63 - 1.00 16.0 - 25.4	0° 52'	180956 804931
	150 1035	150 1035	125 860	2	0.63 - 1.00 16.0 - 25.4	0° 52'	271434 1207397
54 1350	50 345	50 345	50 345	2	0.63 - 1.00 16.0 - 25.4	0° 45'	114511 509371
	100 690	100 690	75 515	2	0.63 - 1.00 16.0 - 25.4	0° 45'	229022 1018741
	150 1035	150 1035	125 860	2	0.63 - 1.00 16.0 - 25.4	0° 45'	343533 1528112
60 1500	50 345	50 345	50 345	2	0.63 - 1.00 16.0 - 25.4	0° 37'	141372 628853
	100 690	100 690	75 515	2	0.63 - 1.00 16.0 - 25.4	0° 37'	282743 1257705
	150 1035	150 1035	100 690	2	0.63 - 1.00 16.0 - 25.4	0° 37'	424115 1886558
66 1650	50 345	50 345	50 345	2	0.63 - 1.00 16.0 - 25.4	0° 37'	171060 760912
	150 1035	150 1035	100 690	2	0.63 - 1.00 16.0 - 25.4	0° 37'	513179 2282735
72 1800	50 345	50 345	50 345	2	0.63 - 1.00 16.0 - 25.4	0° 30'	203575 905548
	100 690	100 690	100 690	2	0.63 - 1.00 16.0 - 25.4	0° 30'	407150 1811095
78 1950	50 345	50 345	50 345	2	0.63 - 1.00 16.0 - 25.4	0° 30'	238918 1062761
	100 690	100 690	75 515	2	0.63 - 1.00 16.0 - 25.4	0° 30'	477836 2125522
84 2100	50 345	50 345	50 345	2	0.63 - 1.00 16.0 - 25.4	0° 30'	277088 1232551
	100 690	100 690	75 515	2	0.63 - 1.00 16.0 - 25.4	0° 30'	554177 2465102
90 2250	50 345	50 345	50 345	2	0.63 - 1.00 16.0 - 25.4	0° 26'	318086 1414918
	100 690	100 690	75 515	2	0.63 - 1.00 16.0 - 25.4	0° 26'	636173 2829837
96 2400	50 345	50 345	50 345	2	0.63 - 1.00 16.0 - 25.4	0° 26'	361911 1609863
	75 515	75 515	50 345	2	0.63 - 1.00 16.0 - 25.4	0° 26'	542867 2414794

- (1) For allowable test or transient pressure, the maximum working pressure may be increased to 1½ times the value shown.
- (2) Pipe end separations shown in the table assume the pipe is in a non-deflected state. Maximum allowable axial pipe movement at the joint is the difference between the maximum and minimum pipe separation. At maximum pipe end separation, axial movement can only occur via pipe expansion into the joint and vice versa.
- (3) Pipe end movement and deflection are non-concurrent.
- (4) Published static deflection values are intended for installation only. For allowable in-service or dynamic deflection, use ½ of the published static values. The coupling closure should be located 90 degrees from the direction of joint deflection.
- (5) The maximum permissible end loads listed in the table are calculated using the nominal pipe O.D. The actual maximum permissible end load will be less or greater than the published figures depending on the actual pipe O.D.

Style 232S Restrained Flexible Coupling

RESTRAINT RINGS

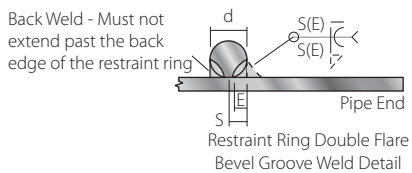
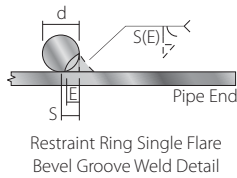
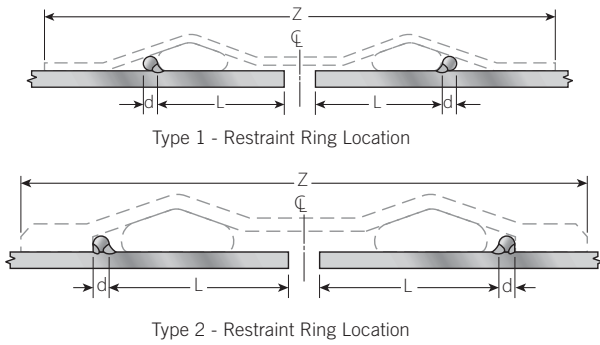

Nominal Pipe Size In./mm	(1) Maximum Working Pressure psi/kPa	(2) Body Type	Width (Z) In./mm	Restraint Ring		
				Diameter (d) In./mm	Location (L) In./mm	Weld Size (E) In.
3 80	300 2065	1	5.25 133.4	1/8	1.44 36.5	1/16
4 100	300 2065	1	5.25 133.4	3/16	1.25 31.8	1/16
6 150	300 2065	1	8.00 203.2	3/16	2.16 54.8	1/16
8 200	200 1375	1	10.00 254.0	1/4	2.75 69.9	3/32
	300 2065	2	10.50 266.7	1/4	3.38 85.7	3/32
10 250	200 1375	1	10.00 254.0	1/4	2.75 69.9	3/32
	250 1725	2	10.5 266.7	1/4	3.38 85.9	3/32
12 300	150 1035	1	10.00 254.0	1/4	2.75 69.9	3/32
	250 1725	2	10.50 266.7	1/4	3.38 85.7	3/32
14 350	100 690	1	10.00 254.0	1/4	2.75 69.9	3/32
	250 1725	2	10.50 266.7	1/4	3.38 85.7	3/32
16 400	75 515	1	10.00 254.0	1/4	2.75 69.9	3/32
	250 1725	2	10.50 266.7	1/4	3.38 85.7	3/32
18 450	50 345	1	10.00 254.0	1/4	2.75 69.9	3/32
	200 1375	2	10.50 266.7	1/4	3.38 85.7	3/32
20 500	25 170	1	10.00 254.0	1/4	2.75 69.9	3/32
	200 1375	2	10.50 266.7	1/4	3.38 85.7	3/32
24 600	25 170	1	10.00 254.0	1/4	2.75 69.9	3/32
	100 690	2	10.50 266.7	1/4	3.38 85.7	3/32
	200 1375	2	12.50 317.5	3/8	4.13 104.8	1/8

- (1) For allowable test or transient pressure, the maximum working pressure may be increased to 1½ times the values shown.
- (2) For applications other than air or gas, where a liquid or other medium is flowing through pipe, restraint ring weld requirements are as follows:
 Type 1 couplings require a full circumferential single flare bevel groove weld based on weld sizes shown in table.
 Type 2 couplings require a full circumferential double flare bevel groove weld based on the weld sizes shown in the table.
 For low pressure air or gas applications, where the weight of the medium flowing through the pipe is not a consideration, a single flare bevel groove weld and/or less than a full circumference of weld may be allowed to attach the restraint rings. Contact Victaulic for specific details. Each restraint ring shipment includes restraint ring placement and welding data that is specific to application or project requirements.
- (3) Restraint rings must be welded perpendicular to the pipe axis with a tolerance of $\pm 1/8^\circ/1.6$ mm.
- (4) Flare bevel groove weld size in table is the minimum requirement. Depth of preparation $S = (d) \div 2$;
 Weld size $E \approx S * 0.625$ per AWS D1.1. For a double flare bevel groove weld, the weld on the back side of the restraint ring must not extend beyond the outermost edge of the ring. The coupling shoulder must have unrestricted contact with the ring and the pipe O.D.

Note: The data in this table only applies when stainless steel couplings are being used on stainless steel pipe.

Style 232S Restrained Flexible Coupling

RESTRAINT RINGS

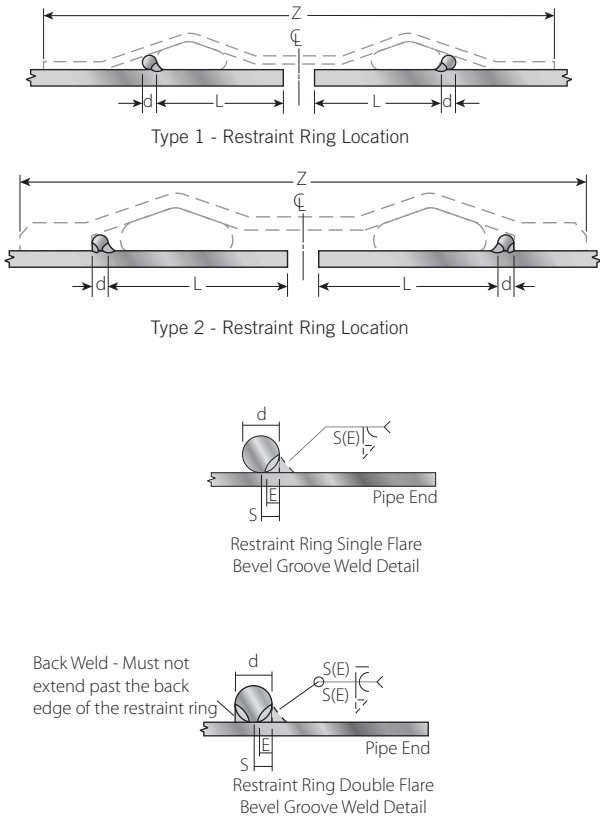

Nominal Pipe Size In./mm	(1) Maximum Working Pressure psi/kPa	(2) Body Type	Width (Z) In./mm	Restraint Ring		
				Diameter (d) In./mm	Location (L) In./mm	Weld Size (E) In.
30 750	100 690	2	10.50 266.7	¼	3.38 85.7	⅜
	150 1035	2	12.50 317.5	⅜	4.13 104.8	½
	200 1375	2	12.50 317.5	⅜	4.13 104.8	½
36 900	100 690	2	10.50 266.7	¼	3.38 85.7	⅜
	150 1035	2	12.50 317.5	⅜	4.13 104.8	½
	175 1200	2	12.50 317.5	⅜	4.13 104.8	½
	200 1375	2	14.50 368.3	½	4.75 120.7	⅝
42 1050	100 690	2	12.50 317.5	⅜	4.13 104.8	½
	150 1035	2	12.50 317.5	⅜	4.13 104.8	½
	200 1375	2	14.50 368.3	½	4.75 120.7	⅝
48 1200	50 345	2	12.50 317.5	⅜	4.13 104.8	½
	100 690	2	12.50 317.5	⅜	4.13 104.8	½
	150 1035	2	14.50 368.3	½	4.75 120.7	⅝
54 1350	50 345	2	12.50 317.5	⅜	4.13 104.8	½
	100 690	2	12.50 317.5	⅜	4.13 104.8	½
	150 1035	2	14.50 368.3	½	4.75 120.7	⅝
60 1500	50 345	2	12.50 317.5	⅜	4.13 104.8	½
	100 690	2	12.50 317.5	⅜	4.13 104.8	½
	150 1035	2	14.50 368.3	½	4.75 120.7	⅝

- (1) For allowable test or transient pressure, the maximum working pressure may be increased to 1½ times the values shown.
- (2) For applications other than air or gas, where a liquid or other medium is flowing through pipe, restraint ring weld requirements are as follows:
 Type 1 couplings require a full circumferential single flare bevel groove weld based on weld sizes shown in table.
 Type 2 couplings require a full circumferential double flare bevel groove weld based on the weld sizes shown in the table.
 For low pressure air or gas applications, where the weight of the medium flowing through the pipe is not a consideration, a single flare bevel groove weld and/or less than a full circumference of weld may be allowed to attach the restraint rings. Contact Victaulic for specific details. Each restraint ring shipment includes restraint ring placement and welding data that is specific to application or project requirements.
- (3) Restraint rings must be welded perpendicular to the pipe axis with a tolerance of $L \pm \frac{1}{16} \times 1.6$ mm.
- (4) Flare bevel groove weld size in table is the minimum requirement. Depth of preparation $S = (d) \div 2$; Weld size $E \approx S * 0.625$ per AWS D1.1. For a double flare bevel groove weld, the weld on the back side of the restraint ring must not extend beyond the outermost edge of the ring. The coupling shoulder must have unrestricted contact with the ring and the pipe O.D.

Note: The data in this table only applies when stainless steel couplings are being used on stainless steel pipe.

Style 232S Restrained Flexible Coupling

RESTRAINT RINGS

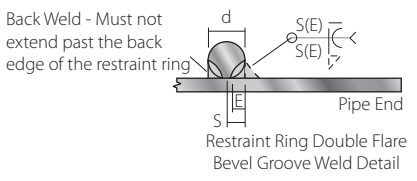
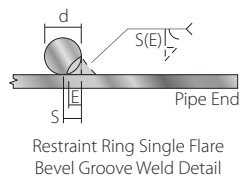
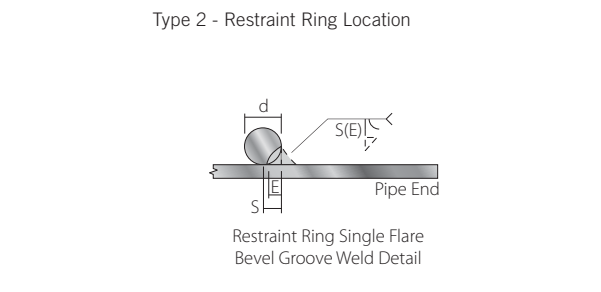
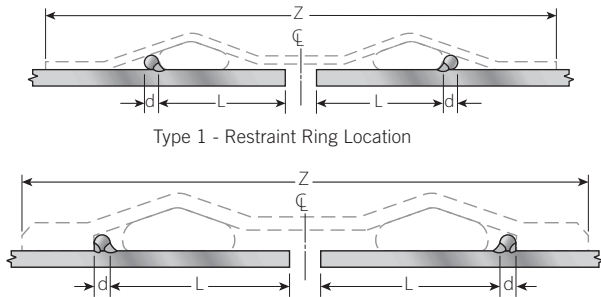

Nominal Pipe Size In./mm	(1) Maximum Working Pressure psi/kPa	(2) Body Type	Width (Z) In./mm	Restraint Ring		
				Diameter (d) In./mm	Location (L) In./mm	Weld Size (E) In.
66 1650	50 345	2	12.50 317.5	3/8	4.13 104.8	1/8
	150 1035	2	14.50 368.3	1/2	4.75 120.7	5/32
72 1800	50 345	2	12.50 317.5	3/8	4.13 104.8	1/8
	100 690	2	14.50 368.3	1/2	4.75 120.7	5/32
78 1950	50 345	2	12.50 317.5	3/8	4.13 104.8	1/8
	100 690	2	14.50 368.3	1/2	4.75 120.7	5/32
84 2100	50 345	2	12.50 317.5	3/8	4.13 104.8	1/8
	100 690	2	14.50 368.3	1/2	4.75 120.7	5/32
90 2250	50 345	2	12.50 317.5	3/8	4.13 104.8	1/8
	100 690	2	14.50 368.3	1/2	4.75 120.7	5/32
96 2400	50 345	2	12.50 317.5	3/8	4.13 104.8	1/8
	75 515	2	14.50 368.3	1/2	4.75 120.7	5/32

- (1) For allowable test or transient pressure, the maximum working pressure may be increased to 1 1/2 times the values shown.
- (2) For applications other than air or gas, where a liquid or other medium is flowing through pipe, restraint ring weld requirements are as follows:
 Type 1 couplings require a full circumferential single flare bevel groove weld based on weld sizes shown in table.
 Type 2 couplings require a full circumferential double flare bevel groove weld based on the weld sizes shown in the table.
 For low pressure air or gas applications, where the weight of the medium flowing through the pipe is not a consideration, a single flare bevel groove weld and/or less than a full circumference of weld may be allowed to attach the restraint rings. Contact Victaulic for specific details. Each restraint ring shipment includes restraint ring placement and welding data that is specific to application or project requirements.
- (3) Restraint rings must be welded perpendicular to the pipe axis with a tolerance of $\pm 1/16$ inch / 1.6 mm.
- (4) Flare bevel groove weld size in table is the minimum requirement. Depth of preparation $S = (d) \div 2$; Weld size $E \approx S * 0.625$ per AWS D1.1. For a double flare bevel groove weld, the weld on the back side of the restraint ring must not extend beyond the outermost edge of the ring. The coupling shoulder must have unrestricted contact with the ring and the pipe O.D.

Note: The data in this table only applies when stainless steel couplings are being used on stainless steel pipe.

Style 232S Restrained Flexible Coupling

CLOSURE TOOLS



MANUAL TOOL



HYDRAULIC TOOL

Manual Tools

- CTM-01: for use on 5" and 8" body widths
- CTM-02: for use on 10" body widths
for use on 12" body widths with thickness of $\frac{3}{16}$ " or less

Hydraulic Tools

- CTH-01*: for use on 12" body widths with thickness of $\frac{1}{4}$ " or greater
for use on 14", 16" and 18" body widths
- CTH-02: for use on all type 3 couplings

- Hydraulic tool package comes standard with:

- one (1) tool head
- one (1) hydraulic cylinder
- one (1) hydraulic hose
- one (1) hand pump

* A CTH-01 hydraulic closure tool can be used in applications where the CTM-02 manual closure tool is recommended.

Note: The closure tools listed above are designed specifically for Victaulic Style 230, 231, 232 and 233 couplings. If ordering custom product, contact Victaulic for appropriate tool selection.

Style 232S Restrained Flexible Coupling

PRODUCT CONFIGURATOR

C 0232 0096 50 X 2 C E O X XO

Class	Style	Actual Pipe O.D.*		Body Type	Segments	PSI/kPa Rating	Rubber Compound	Paint	Hardware	Ring and Pipe Material
		Inches [^]	Fraction							
C	0232	0002 through 0102	00 - 0 13 - 1/8 25 - 1/4 38 - 3/8 50 - 1/2 63 - 5/8 75 - 3/4 88 - 7/8	X - Stainless	1 - One 2 - Two	A - 25/170 B - 50/345 C - 75/515 D - 100/690 E - 125/860 F - 150/1035 G - 175/1200 H - 200/1375 J - 250/1725 K - 300/2065	E - EPDM I - Isoprene L - Silicone T - Nitrile V - Neoprene O - Fluoro-elastomer	0 - None	X - Stainless	XO - Stainless Steel Ring on Stainless Steel Pipe SO - Carbon Steel Ring on Carbon Steel Pipe DO - Carbon Steel Ring on Ductile Iron Pipe

[^] Couplings are available in a range of nominal sizes from 3 - 96".
 * For actual pipe O.D. round down to the nearest 1/8" to determine proper coupling size required.

ENGINEERED PRODUCTS OPTIONS

For non-standard products the Victaulic Engineered Products group can assist with specialty joints designed to meet the specific size, pressure and temperature requirements of your system.

WARRANTY

Refer to the Warranty section of the current Price List or contact Victaulic for details.

NOTE

This product shall be manufactured by Victaulic or to Victaulic specifications. All products to be installed in accordance with current Victaulic installation/assembly instructions. Victaulic reserves the right to change product specifications, designs and standard equipment without notice and without incurring obligations.

TESTING

Victaulic Style 232S couplings are designed to allow for a 50 percent increase over the published maximum working pressure for test and/or transient pressures. Due to the huge volume of air that can be involved in jobsite air testing and the nature of air or gas that is pressurized, jobsite air testing should be limited to 25 psi/175 kPa or less.

Victaulic offers a dished head assembly prepared with a restraint ring for the Style 232S coupling for field testing a section of pipeline or to end a pipeline and allow for future expansion. Contact Victaulic for details.

For complete contact information, visit www.victaulic.com

60.06 3367 REV J UPDATED 08/2013

VICTAULIC IS A REGISTERED TRADEMARK OF VICTAULIC COMPANY. © 2013 VICTAULIC COMPANY. ALL RIGHTS RESERVED.

