

Butterfly Valve

SERIES 7B2



The Series 7B2 butterfly valve features a weatherproof actuator housing approved for indoor or outdoor use for domestic water or combined domestic water/fire protection services. It has a ductile iron body and disc with an EPDM coating. The body is coated with a heat fused polyphenylene sulfide blend. For fire protection services, the Series 7B2 valve is cULus Listed and FM Approved for 175 psi/1206 kPa service. They are also NSF certified per ANSI NSF-61-G for cold 73°F/23°C potable water service.

Weatherproof Actuator

Supervisory switches for valves are standard on sizes 2 1/2 – 10"/65 – 250mm pre-wired (PW). Switches are set up to supervise the valve in the open position.

Tapped Outlets

Series 7B2 valves can be ordered with optional 3/4" NPT tapped outlets, two upstream and two downstream of the disc. Locations of these ports are detailed by the diagram on page 2. Tapped port locations are capable of including two 3/4" FNPT ports on each side of the valve (up to four total). The 6"/150 mm size valve comes standard with four tapped ports.



MATERIAL SPECIFICATIONS

Body: Ductile iron conforming to ASTM A-536, grade 65-45-12, coated with polyphenylene sulfide blend

Disc: Ductile iron conforming to ASTM A-536, EPDM coating

Disc Coating:

- **Grade "E" EPDM**

EPDM (Green color code). Temperature range -30°F to +230°F/-34°C to +110°C. Recommended for cold and hot water service within the specified temperature range plus a variety of dilute acids, oil-free air and many chemical services. NOT RECOMMENDED FOR PETROLEUM SERVICES.*

Stem Bearings: Teflon with stainless steel backing

Stem Nuts: Type 416 Stainless Steel

O-Ring: EPDM

Plugs for Optional Ports: Bronze, C89833 per ASTM B584 or C65100 per ASTM B98

Bracket: Carbon steel, painted

Actuator:

- 2 1/2 – 8"/65 – 200 mm: Bronze traveling nut on a steel lead screw, in a cast iron housing
- 10"/250 mm: Steel worm and cast iron quadrant gear, in a cast iron housing

* Services listed are General Service Recommendations only. It should be noted that there are services for which these seals are not recommended. Reference should always be made to the latest Victaulic Gasket Selection Guide for specific service recommendations and for a listing of services which are not recommended.

JOB/OWNER

System No. _____

Location _____

CONTRACTOR

Submitted By _____

Date _____

ENGINEER

Spec Sect _____ Para _____

Approved _____

Date _____

Butterfly Valve

SERIES 7B2

DIMENSIONS

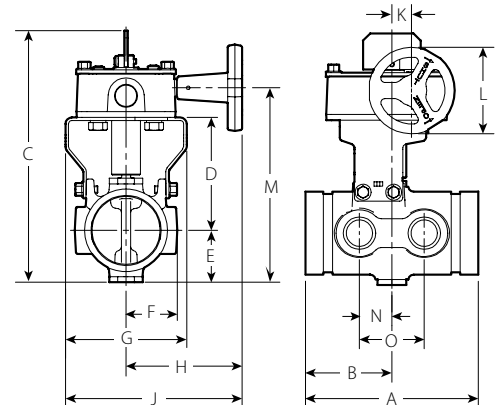

Valve Size		Dimensions – Inches/millimeters															Approx. Wgt. Ea. Lbs./kg
Nominal Diameter Inches mm	Actual Out. Dia. Inches mm	E to E A	B	Height C	D	E	F	G*	H	J	K	L	M	N	O		
2½ 65	2.875 73.0	6.00 152	3.00 76	9.80 249	3.92 100	1.80 46	1.78 45	5.30 135	5.45 138	8.10 206	0.97 25	4.50 114	6.97 177	1.13 29	2.25 57	9.4 4.2	
3 80	3.500 88.9	6.25 159	3.12 79	10.48 266	4.28 109	2.14 54	2.10 53	5.30 135	5.45 138	8.10 206	0.97 25	4.50 114	7.61 193	1.28 33	2.56 65	10.2 4.6	
4 100	4.500 114.3	6.63 168	3.32 84	11.89 302	4.65 118	2.71 69	2.60 66	5.88 149	5.45 138	8.39 213	0.97 25	4.50 114	9.05 230	1.38 35	2.75 70	15.8 7.1	
6 150	6.625 168.3	7.00 178	3.50 89	13.74 349	5.65 144	3.61 92	3.60 91	7.63 194	5.45 138	9.27 236	0.97 25	4.50 114	10.92 277	1.67 42	3.33 85	26.0 11.7	
8 200	8.625 219.1	8.00 203	4.00 102	16.92 430	7.94 202	5.00 127	5.40 137	10.80 274	8.28 210	13.68 348	2.05 52	6.00 152	14.06 357	1.84 47	3.69 94	54.0 24.3	
10 250	10.750 273.0	8.00 203	4.00 102	19.18 487	8.68 221	5.84 148	6.19 157	12.38 325	8.34 212	14.53 369	2.05 52	9.00 229	15.90 404	1.88 48	3.76 96	80.0 39.3	

* Indicates maximum envelope width.

1. To prevent rotation of valves, it is recommended that Series 7B2 valves be installed with a Victaulic rigid coupling.
2. When the Series 7B2 valve is used on Class 53/54 ductile iron pipe, a Style 307 transition coupling must be used.
3. When the Series 7B2 valve is used in conjunction with a PPS coated Series 717 check valve for dual entry water systems, a Style 107H or 07 coupling must be used to join the two valves together. Contact Victaulic for details.
4. Victaulic grooved end Series 7B2 butterfly valves are permitted for use with grooved end (IPS) pipe or grooved end cast ductile iron pipe only. Not permitted for use with plain end pipe.
5. Series 7B2 valves are designed for indoor/outdoor service and are not intended for wash down and submersible service.

Butterfly Valve

SERIES 7B2

PERFORMANCE

The chart expresses the frictional resistance of Victaulic Series 7B2 in equivalent feet/meters of straight pipe.

Valve Size			Valve Size		
Nominal Diameter Inches/mm	Actual Outside Diameter Inches/mm	Equivalent Feet/m of Pipe	Nominal Diameter Inches/mm	Actual Outside Diameter Inches/mm	Equivalent Feet/m of Pipe
2½ 65	2.875 73.0	5 1.6	6 150	6.625 168.3	8 2.5
3 80	3.500 88.9	5 1.6	8 200	8.625 219.1	11 3.4
4 100	4.500 114.3	12 3.7	10 250	10.750 273	12 3.7

C_v/K_v Values

C_v/K_v values for flow of water at +60°F (+16°C) with a fully open valve are shown in the table below. For additional details contact Victaulic.

Formulas for C_v/K_v Values:

$$\Delta P = \frac{Q^2}{C_v^2}$$

$$Q = C_v \times \sqrt{\Delta P}$$

Where:

Q = Flow (GPM)
 ΔP = Pressure Drop (psi)
 C_v = Flow Coefficient

$$\Delta P = \frac{Q^2}{K_v^2}$$

$$Q = K_v \times \sqrt{\Delta P}$$

Where:

Q = Flow (m³/h)
 ΔP = Pressure Drop (bar)
 K_v = Flow Coefficient

Valve Size			Valve Size		
Nominal Diameter Inches/mm	Actual Outside Diameter Inches/mm	C _v /K _v (Full Open)	Nominal Diameter Inches/mm	Actual Outside Diameter Inches/mm	C _v /K _v (Full Open)
2½ 65	2.875 73.0	325 277	6 150	6.625 168.3	1850 1578
3 80	3.500 88.9	482 411	8 200	8.625 219.1	3400 2900
4 100	4.500 114.3	600 512	10 250	10.750 273	5750 4905

Butterfly Valve

SERIES 7B2

SWITCH AND WIRING

1. The supervisory switch contains two single pole, double throw, pre-wired switches.
2. Switches are rated:
 - 10 amps @ 125 or 250 VAC/60 Hz
 - 0.50 amps @ 125 VDC
 - 0.25 amps @ 250 VDC
3. **Switches supervise the valve in the "OPEN" position.**
4. One switch has two #18 insulated wires per terminal, which permit complete supervision of leads (refer to diagrams and notes below). The second switch has one #18 insulated wire per terminal. This double circuit provides flexibility to operate two electrical devices at separate locations, such as an indicating light and an audible alarm, in the area that the valve is installed.
5. A #14 insulated ground lead (green) is provided.
 - Switch #1 = S1 For connection to the supervisory circuit of a UL Listed alarm control panel
 - Switch #2 = S2 Auxiliary switch that may be connected to auxiliary devices, per the authority having jurisdiction

- S1** { Normally Closed: (2) Blue
Common: (2) Yellow
- S2** { Normally Closed: Blue with Orange Stripe
Normally Open: Brown with Orange Stripe
Common: Yellow with Orange Stripe

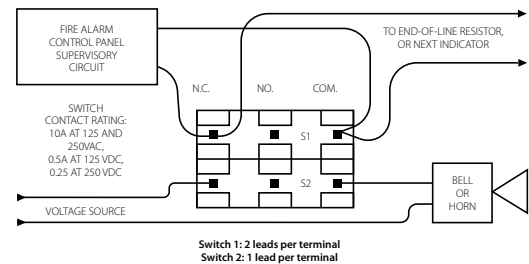
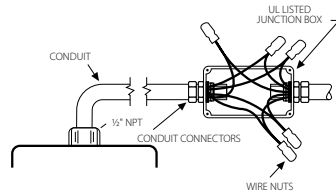

NOTE: The above diagram shows a connection between the common terminal (yellow – S1 and yellow-with-orange stripe – S2) and the normally closed terminal (blue – S1 and blue-with-orange stripe – S2). In this example, the indicator light and alarm will stay on until the valve is fully open. When the valve is fully open, the indicator light and alarm will go out. Cap off any unused wires (e.g. brown with orange stripe).

Only S1 (two leads per terminal) may be connected to the fire alarm control panel.

The connection of the alarm switch wiring shall be in accordance with NFPA 72 and the auxiliary switch per NFPA 70 (NEC).

WARRANTY

Refer to the Warranty section of the current Price List or contact Victaulic for details.

NOTE

This product shall be manufactured by Victaulic or to Victaulic specifications. All products to be installed in accordance with current Victaulic installation/assembly instructions. Victaulic reserves the right to change product specifications, designs and standard equipment without notice and without incurring obligations.

For complete contact information, visit www.victaulic.com

10.12 1430 REV C UPDATED 06/2012

VICTAULIC IS A REGISTERED TRADEMARK OF VICTAULIC COMPANY. © 2012 VICTAULIC COMPANY. ALL RIGHTS RESERVED.

10.12

