



Patented

### 1.0 PRODUCT DESCRIPTION

#### Grooving Capability

- Fully automated 4 – 12"/DN100 – DN300 Original Groove System (OGS) and 14 – 16"/DN350 – DN400 Advanced Groove System (AGS).
- Semi-automated 18 – 24"/DN450 – DN600 AGS. Once groove is complete the operator must manually measure "C" dimension with a Go/No-Go Tape.

#### Application

- Production roll grooving tool designed for fabrication shop use
- Designed to roll groove Schedule 10-40 carbon steel pipe
- Supplied with OGS and AGS roll sets
- Provides traceable measurements that can be recorded locally or exported as required
- Integrated sensors and instrumentation measure and record all critical groove dimensions including Groove Diameter (C), Flare (F), Gasket Seat (A), Groove Width (B) and OD (pipe outside diameter)

#### Performance

Tool Ratings — Maximum Pipe Size Capacity		Pipe Size (in/IDN)/Schedule <sup>1</sup>											
		4 100	5 125	6 150	8 200	10 250	12 300	14 350	16 400	18 450	20 500	22 550	24 600
RG5200i	Carbon Steel	10 – 40 (OGS)						Standard Wall (AGS)					
		Automatic						Semi-Automatic					

<sup>1</sup> Light wall pipe can only be grooved in OGS sizes.

- The RG5200i is capable of grooving 26 – 60"/650 – 1500 mm carbon steel pipe. The grooving operation for these sizes is not automated and utilizes traditional Victaulic roll sets. Contact Victaulic for additional information

#### NOTES

- Victaulic roll grooving tools cold-form a groove into the pipe. The lower roll (driving roll) rotates the pipe while the upper roll (forming roll) is hydraulically driven into the pipe to form the groove.
- Roll sets for the RG5200i are not compatible with other Victaulic grooving tools.
- RG5200i Roll Grooving Tools are capable of grooving short pipe lengths. Refer to RG5200i Tool Operation Manual TM-RG5200i for details.
- Final measurements are presented to the operator in a color-coded, Pass/Fail Format.
- Ethernet capabilities enable remote trouble shooting, software uploads and data transactions.
- Equipped with an adjustable proximity sensor system to maintain a safe working distance around the tool.

**ALWAYS REFER TO ANY NOTIFICATIONS AT THE END OF THIS DOCUMENT REGARDING PRODUCT INSTALLATION, MAINTENANCE OR SUPPORT.**

System No.		Location	
Submitted By		Date	

Spec Section		Paragraph	
Approved		Date	

## 2.0 CERTIFICATION/LISTINGS

---

Product designed and manufactured under the Victaulic Quality Management System, as certified by LPCB in accordance with ISO-9001:2008.

---

## 3.0 SPECIFICATIONS

---

**Drive Requirements:** Self-contained

**Power Requirements:** 18 Amp, 208-240 VAC three-phase power, 50/60 Hz

- Tool requires certified electrician for electrical connection
  - Tool requires internet connection, operating outside company firewall
  - Tool requires commission by certified Victaulic representative
- 

## 4.0 ACCESSORIES/REPLACEMENT PARTS

---

- One (1) RG5200i Pipe Roll Grooving Tool with Stabilizer Assembly and Support Base/Handrails
- One (1) Control Station
- One (1) VAP131R Hydraulic, Adjustable Pipe Stand with Tracks
- One (1) Roll Set for 8 – 12 inch Steel Pipe Pre-Installed on the Tool
- One (1) Roll Set for 4 – 6 inch Steel Pipe OGS Specifications
- One (1) Roll Set for 14 – 24 inch Steel Pipe AGS Specifications
- One (1) Guard Setting Pad (OGS)
- One (1) Guard Setting Pad (AGS)
- One (1) Electrical Cable
- Seventy-five (75) Reflective Targets

Victaulic VAP131R is required and is critical for proper operation of the RG5200i

## 5.0 DIMENSIONS

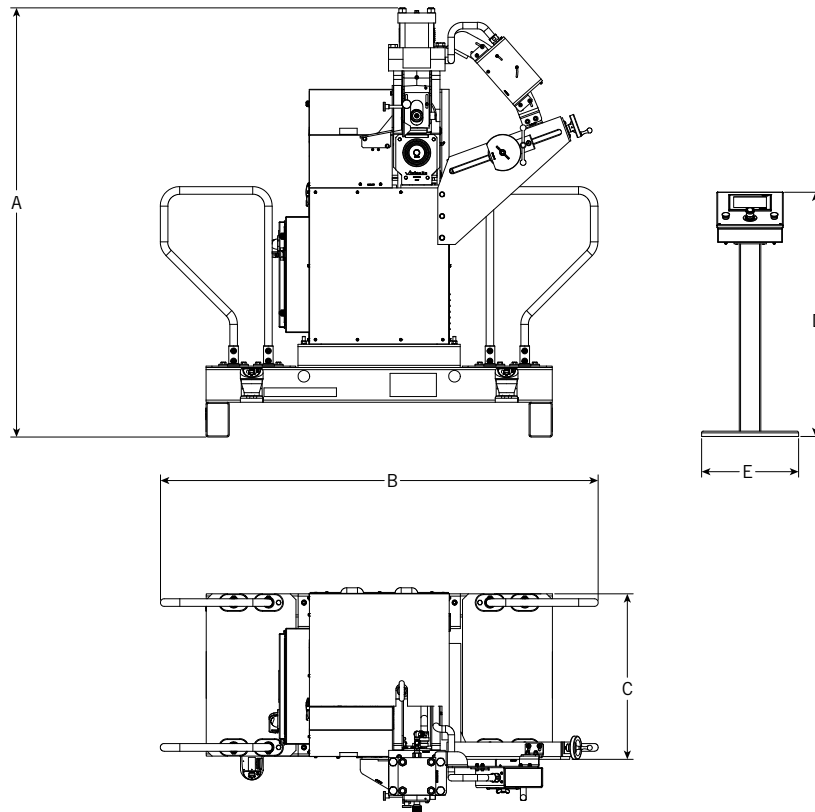

	Dimensions					Tool Weight lb kg
	A inches mm	B inches mm	C inches mm	D inches mm	E inches mm	
RG5200i Tool	62.13 1578	76.00 1930	29.00 737	– –	– –	1300 590
Operator Station	– –	– –	– –	45.38 1153	18.00 457	54.0 24.0

### NOTES

- Refer to TM-RG5200i Operation and Maintenance Instruction Manual for power, installation and tool operation requirements.
- 3 feet (1 meter) of space between wall and back of tool for maintenance operations is required. Select a location for the tool, control station, and pipe stand by taking into consideration a permanent indoor location with a level concrete floor.

## 5.0 DIMENSIONS (Continued)

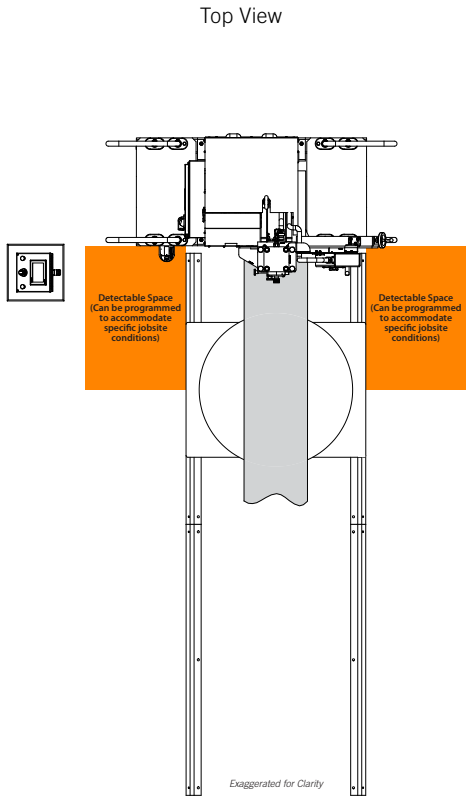

Figure 1

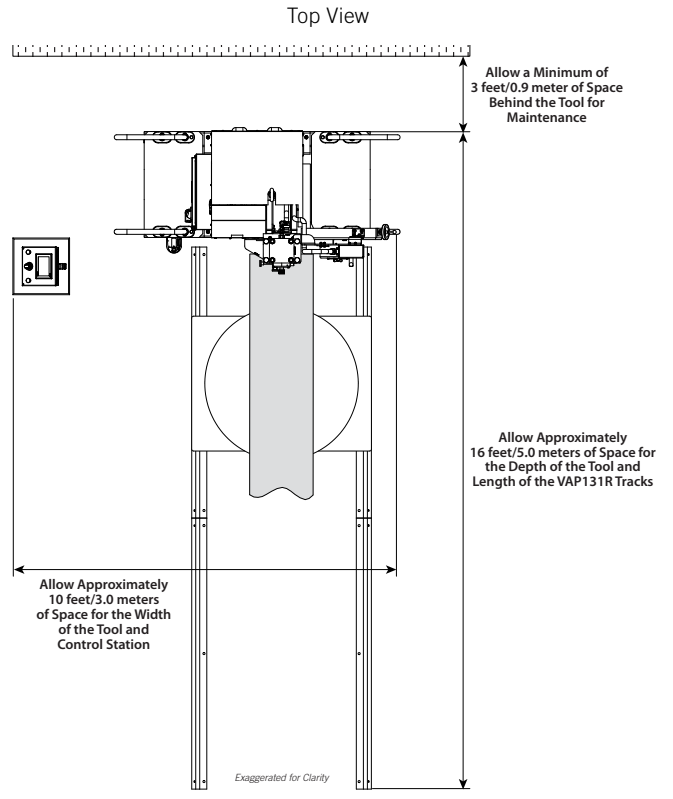

Figure 2

Orange zone indicates work area protected by the safety proximity sensor. Work area is adjustable based on location and situation.

## 6.0 NOTIFICATIONS

### WARNING



Failure to follow instructions and warnings could result in serious personal injury.

- Before operating or servicing this tool, read all instructions in the operating and maintenance manual and all labels on the tool.
- Wear safety glasses, hardhat, foot protection, and hearing protection.

If you have questions concerning the safe and proper operation of this tool, contact Victaulic, P.O. Box 31, Easton, PA 18044-0031, Phone: 1-800-PICKVIC, E-Mail: pickvic@victaulic.com.

### WARNING

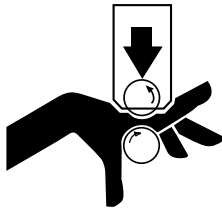

#### Grooving rolls can crush or cut fingers and hands.

- Always disconnect the tool from the power source before making any tool adjustments.
- Make sure the guard is adjusted properly before grooving pipe.
- Loading/unloading pipe will place your hands close to the grooving rolls. Keep hands away from the grooving rolls and the roller on the pipe stabilizer during operation.
- Never reach inside the pipe ends or across the tool or pipe during operation.
- Never groove pipe that is shorter than the recommended lengths listed in the operating and maintenance manual.
- Never wear loose clothing, loose gloves, or anything that can become entangled in moving parts.

2244 Rev. D

R007276LBL

- Two-hand activation is required to start the tool
- If the safety zone is breached, the tool will automatically suspend operation
- In order to achieve Victaulic specified product performance, the proper Victaulic roll grooving tool and corresponding Victaulic roll set must be selected. Failure to select the appropriate Victaulic roll set, or to use the correct Victaulic tool, may result in reduced performance or product failure. Tool specifications and capacities are listed with each tool.

## 7.0 REFERENCE MATERIALS

---

[TM-RG5200i Operation and Maintenance Instruction Manual](#)

[I-100 Installation and Maintenance Manual](#)

[Vic-Easy Adjustable Pipe Stand -VAPS 131R](#)

[24.01: Pipe Preparation Tools Submittal](#)

---

### User Responsibility for Product Selection and Suitability

Each user bears final responsibility for making a determination as to the suitability of Victaulic products for a particular end-use application, in accordance with industry standards and project specifications, and the applicable building codes and related regulations as well as Victaulic performance, maintenance, safety, and warning instructions. Nothing in this or any other document, nor any verbal recommendation, advice, or opinion from any Victaulic employee, shall be deemed to alter, vary, supersede, or waive any provision of Victaulic Company's standard conditions of sale, installation guide, or this disclaimer.

### Intellectual Property Rights

No statement contained herein concerning a possible or suggested use of any material, product, service, or design is intended, or should be construed, to grant any license under any patent or other intellectual property right of Victaulic or any of its subsidiaries or affiliates covering such use or design, or as a recommendation for the use of such material, product, service, or design in the infringement of any patent or other intellectual property right. The terms "Patented" or "Patent Pending" refer to design or utility patents or patent applications for articles and/or methods of use in the United States and/or other countries.

### Note

This product shall be manufactured by Victaulic or to Victaulic specifications. All products to be installed in accordance with current Victaulic installation/assembly instructions. Victaulic reserves the right to change product specifications, designs and standard equipment without notice and without incurring obligations.

### Installation

Reference should always be made to the Victaulic installation handbook or installation instructions of the product you are installing. Handbooks are included with each shipment of Victaulic products, providing complete installation and assembly data, and are available in PDF format on our website at [www.victaulic.com](http://www.victaulic.com).

### Warranty

Refer to the Warranty section of the current Price List or contact Victaulic for details.

### Trademarks

*Victaulic* and all other Victaulic marks are the trademarks or registered trademarks of Victaulic Company, and/or its affiliated entities, in the U.S. and/or other countries.